

THE DALEK

**BUILD
THE ICONIC
BBC**



MONSTER



**GENESIS OF
THE DALEKS
PART THREE**



**STEP-BY-STEP
INSTRUCTIONS**

Published
weekly • £11.99
AUS • \$23.99



10
9 772977 557054

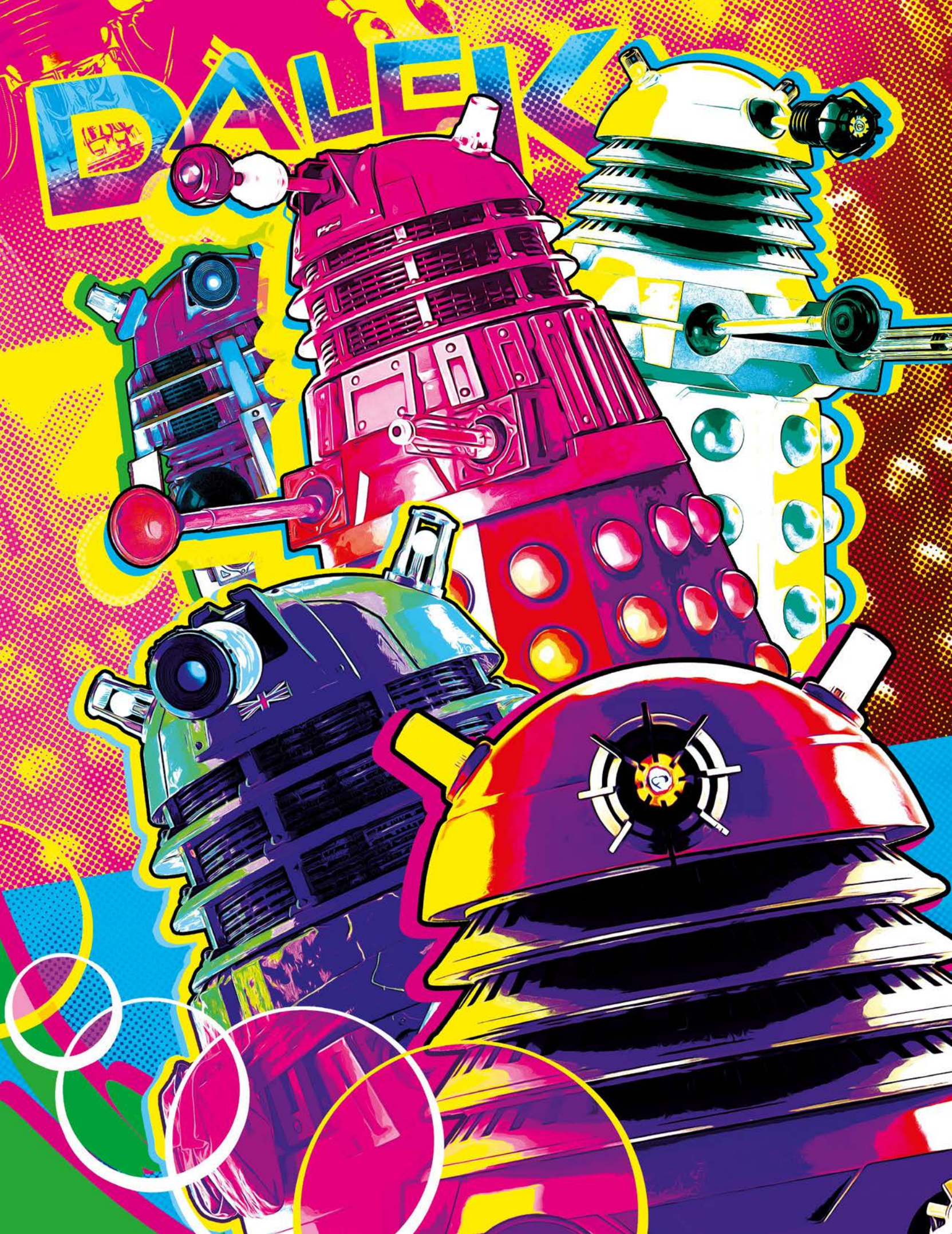

DALEK

ISSUE 10

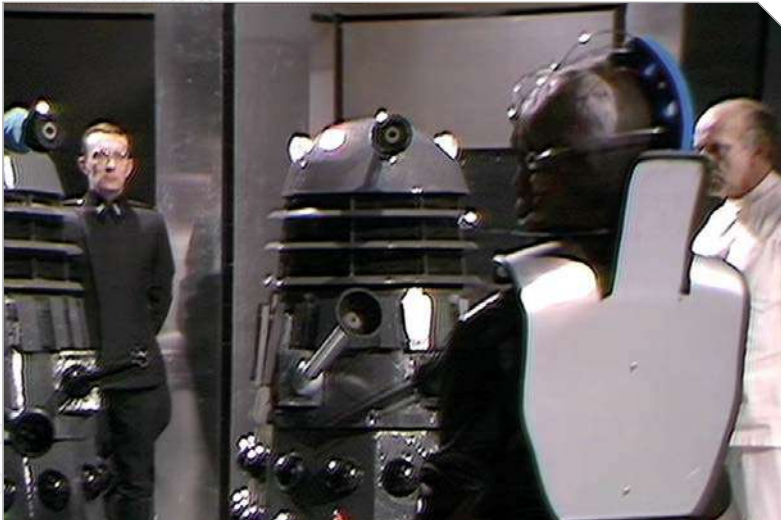

ADVENTURES IN TIME AND SPACE: GENESIS OF THE DALEKS: PART THREE 4

Davros betrays his own people to secure a future for his Daleks.



STEP-BY-STEP BUILD: PART 10 8

Dome panel and parts for the eye-stalk mechanism.

Reader Services

CUSTOMER SERVICE IN THE UK
AND REPUBLIC OF IRELAND

How to continue your collection:

Subscribe online at hachettepartworks.com/Dalek or contact the Customer Service team via hachettepartworks.com/contact

Customer service & back orders:

Please visit hachettepartworks.com/contact to get in touch.

UK call 0345 155 9277

ROI call (01) 9079762

(Calls are charged at your local rate from a landline)

Published by Hachette Partworks Ltd
4th Floor, Jordan House, 47 Brunswick Place, London N1 6EB

General Manager – Isabelle Couderc
Editorial Director – Helen Nally
Marketing Director – Elise Windmill
Production Director – Sema Sant Anna
Managing Editor – Sarah Gale
Distribution Manager – Paul Smith
Product Manager – Rhys Myner

Packaged by Panini Publishing, a division of Panini UK Limited.

Publishing Director Europe – Marco M. Lupoi
Managing Director – Chris Clover
Managing Editor – Alan O'Keefe
Senior Editor – Ed Hammond
Editor – John Ainsworth
Designer – Barry Spiers
Features Writer – Stuart Ashley

Distributed in the UK and Republic of Ireland by Marketforce.

© 2025 Hachette Partworks Ltd

Printed in the UK.

ISSN 2977-5574

ALL RIGHTS RESERVED

The editor's policy is to use papers that are natural, renewable and recyclable products and made from wood grown in sustainable forests. The logging and manufacturing processes are expected to conform to the environmental regulations of the country of origin.

In the event of a significant increase in production and transport costs, the publisher reserves the right to modify its selling prices.

BBC, DOCTOR WHO, TARDIS and DALEK (word marks and devices) are trade marks of the British Broadcasting Corporation and are used under licence. BBC logo © BBC 1996. DOCTOR WHO logo © BBC 1973. Dalek image © BBC/Terry Nation 1963. Licensed by BBC Studios.

All parts belong to a kit. NOT SUITABLE FOR CHILDREN UNDER THE AGE OF 14. This product is not a toy and is not intended for use in play. Follow the instructions in the enclosed magazines carefully and keep the appropriate information in a safe place. The installation of the electrical and electronic parts must always be carried out by an adult. Requires batteries.



For our environmental policy in full please scan the QR code here.

hachette
PARTWORKS LTD

WHAT TO DO WITH YOUR PACKAGING?

Our packaging papers and boxes are 100% recyclable kerbside. Plastic blisters can also be 100% recyclable kerbside once separated from the cardboard. To find out what you can recycle at home and locally, please visit www.recyclenow.com

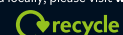

GENESIS OF THE DALEKS

PART THREE

The Doctor warns the Kaleds of the Dalek threat, but Davros is one step ahead.

Season 12 Episode 13
First Broadcast: 22nd March 1975

A squad of Thal soldiers, armed with rifles, arrive in the rocket silo and start shooting at the escaping prisoners high above them. Some of the Mutos are hit and fall to their deaths. The Kaled officer is also killed. Sarah is frozen in fear. Sevrin urges her to keep climbing. Sarah reaches for the next railing but slips. She screams as she falls, but luckily hits a wooden platform. Sevrin climbs down and helps her up. Another prisoner is shot and falls to his death, leaving only Sarah and Sevrin still alive. They reach the top of the scaffolding and see the rocket's nose cone. The top of the Thal dome is just above it. "A section of the roof slides open," Sevrin explains. "We can get to it from the top of the rocket." Sarah looks down at the gap between the scaffolding and the rocket, and the dizzying drop to the silo's floor. Sevrin senses her fear. "We'll have to jump," he says. "Now, I'll go first, you follow, and I'll catch you." Sevrin safely makes the jump onto the rocket and beckons Sarah to follow. She hesitates, then does so.





Sevrin climbs to the top of the nose cone, but he is too late; two Thal guards have climbed up high enough to fire a warning shot. He is forced to return to Sarah. Sevrin crosses back to the platform, but again Sarah hesitates. "Now you! Move!" one of the guards shouts. Sarah stays where he is. The guard jumps across and pretends to help – but then pushes her off the nose cone. Holding her arm to stop her falling further, he taunts Sarah. "They say people who fall from great heights are dead before they



hit the ground," the guard says, his lips contorted in a cruel smile. "I don't believe that, do you?" He pulls Sarah back up to safety. "You're going back to work," he says. "In a day or so you'll wish I had let you drop."

The Doctor and Harry move cautiously through the rocky tunnels connected to the Kaled bunker. They find a metal grill. "That must be the way through to the Wastelands," Harry comments. He moves forward, his attention on the grill, failing to see a large clam-like creature on the ground. Harry's foot is trapped inside it and he screams in pain. The Doctor tries to pull him free, with no success. He grabs a large rock and brings it crashing down on the clam several times, but this has no effect either. "Quick!" Harry yells. The Doctor wrenches off a stalactite and shoves it into the clam's mouth, using it as a lever. He prises the mouth open just long enough for Harry to get his leg out. The Doctor realises that the creature must be one of Davros' early genetic experiments. He examines Harry's leg and is relieved to see that no bones have been broken. "Why is it always me that puts his foot in it?!" Harry asks. The Doctor puts his hands around the corroded bars of the grill and begins to pull them apart...

Inside the Kaled bunker, two Daleks approach Davros. "We await your commands," they say. A scientist, Kavell, praises Davros, calling the Daleks a "perfect creation". But Davros disagrees and orders a series of improvements to be made. Kavell uses a moment alone



with Ronson to ask if Davros knows that the prisoners have escaped. Ronson pretends not to know what he means, but Kavell promises that he won't betray him. "You're not the only one concerned about the morality of the work we are doing here," he whispers. Kavell tells Ronson that he has had word that the Doctor and Harry have made contact with the officials in the Kaled dome. Neither man notices that they are being watched by Security Commander Nyder...



MICHAEL WISHER

Michael Wisher (1935-1995) began his TV career in episodes of *Suspense*, *Your World* and *Z-Cars* in the early 1960s. His first roles in *Doctor Who* were as John Wakefield in *The Ambassadors of Death* (1970), Rex Farrel in *Terror of the Autons* (1971) and Kalk in *Carnival of Monsters* (1973). Wisher also voiced the Daleks in *Frontier in Space* (1973) and *Planet of the Daleks* (1973), and therefore seemed a natural choice to play their creator Davros. Wisher rehearsed the role sitting in a chair with a paper bag over his head, aware that the mask would allow him no expression during recording. He based his vocal performance on the British philosopher and mathematician Bertrand Russell.



The Ambassadors of Death



Michael Wisher plays Rex Farrel in *The Terror of the Autons*.



Back at the Thal rocket silo, more Mutos continue to load the dystronic explosive cannisters, exposing their bodies to the deadly chemical. An exhausted Sarah and Sevrin are among them. They know their time is running out...



in the bunker, a concerned Nyder approaches Davros. He has received word that Mogran has called a secret meeting, and the only councillors invited are opponents of the work being carried out in the bunker. Davros remains calm. "Many times in the last 50 years, factions of the government have tried to interfere with my research here," he states. "They have failed. They will fail again." But Nyder then says that the Doctor and Harry have been sighted at the Kaled dome with Mogran. Davros realises that he has been betrayed by Ronson. He tells Nyder that he will deal with him...

A Kaled official, Councillor Mogran, has met with the Doctor and Harry. He calls a secret meeting of Kaled councillors at their command headquarters. The Doctor explains to them that "Davros has created a machine creature; a monster which will terrorise and destroy millions and millions of lives and lands throughout all eternity. He has given this machine a name: a Dalek." The councillors listen as the Doctor solemnly states that the fate of the universe is hanging on their decision...

At the Kaled command headquarters, Mogran tells the Doctor and Harry that the councillors have agreed to suspend Davros' work on the Daleks until a full investigation can be made. The Doctor and Harry decided to search for Sarah. General Ravon overhears and tells them that he has received a report of a female prisoner leading an escape attempt inside the Thal rocket



GUY SINER



Guy Siner was born in 1947. He began his TV career with episodes of *Z-Cars* and *Softly Softly: Taskforce*. "I think I was in awe of Tom [Baker] because he was the star of the show and a very powerful character," he recalled. "[Ravon] was a jumped-up boy general and had been promoted way beyond his abilities, simply because everybody else had been killed because the war had been going on for so long." Director David Maloney had a specific request for Siner's performance: "I remember I was directed to speak almost like a Dalek, with that kind of passionate intensity and unthinking obedience." *Genesis of the Daleks* had a hurried schedule even by *Doctor Who's* standards: "It was shot as live, so you would literally

run from one set to another, because when the camera cut, if you were walking through the door you had to be there, regardless of what you were doing in the previous scene. It was very exciting." Siner went on to international fame thanks to his portrayal of Lieutenant Gruber in the long-running sitcom *'Allo 'Allo!*

PETER MILES





Inside the bunker, Davros affects a tone of happy compliance when he is met with Mogran's demands to suspend all his work. "It will take some time to close down certain pieces of equipment," Davros says. "Shall we say 24 hours?" Mogran shortens the deadline to 12. Satisfied, he departs. Nyder is appalled, but Davros is triumphant: "The Council has signed the death warrant of the whole of the Kaled people. Only we and the Daleks will go on!" Even the ruthless Nyder is shaken by Davros' words. "The whole of the Kaled people? You would go that far?" he asks. Davros orders that 20 of the Dalek mutants be placed inside the machine casings. Nyder protests that the creatures are



too erratic to be trusted, but Davros plans to limit them with a computer programme. Davros adds that he and Nyder will soon be going on a journey...

Later, the Doctor and Harry make their way into the Thal dome. They spy Davros and Nyder through a window, conferring with Thal officials. They listen as Davros betrays his own people, offering the Thals a way to weaken the Kaled dome so that their rocket can destroy it. Davros claims that he only wishes to end Skaro's eternal



war. "By dawn tomorrow, our world could be at peace..."

The Doctor knock out two guards and steal their protective suits. They make their way to the rocket silo in disguise. Sarah and Sevrin are there. The pair have realised that the Thals intend to kill them with the rocket's exhaust flames. The Doctor and Harry knock out the Thal guard and reveal themselves, much to Sarah's joy. The Doctor tells



everyone to get back to the Kaled dome while he sabotages the rocket. Left alone, the Doctor examines the rocket, unaware that the guard is regaining consciousness. As the Doctor touches the scaffolding, the guard crawls to a control panel and hits a button. The metal grating is suddenly flooded with a massive electrical charge. The Doctor is pinned to the grating by the energy, his face contorted in agony...



PETER DAY

Peter Miles (1928–2018) joined the Birmingham Repertory Theatre in the mid-1960s and got his first television work a few years later. Nyder is still regarded as one of the greatest villains in the show's history – no small achievement when you consider that he was partnered with Michael Wisher's Davros. Peter Miles discovered that he and Elisabeth Sladen lived close to each other, and so began to give her lifts in his car to BBC Centre during their time making *Genesis of the Daleks*. They became lifelong friends.

Peter Miles as Professor Whitaker in *Invasion of the Dinosaurs*.



Peter Day (1927-2023) was a senior designer at the BBC's Visual Effects Department for over 30 years. He designed and created models, props and pyrotechnics for TV series such as *The Goodies*, *Dad's Army*, *Blue Peter* and, of course, *Doctor Who*. His first work on the series was for *The Evil of the Daleks* (1967). Day drew the initial design sketches of Davros and constructed the mobile chair for the character. Another of his tasks was to build the model of the Thal rocket. Used to working on a limited budget, Day reworked the model he had already built for the Recovery rocket seen in *The Ambassadors of Death* (1970).

DALEK DOME

DOMe PANEL AND PARTS FOR EYE-STALK MECHANISM



COMPONENTS OF ISSUE 10

10A	TOP PANEL	10D	TWO BEARING RINGS	<input type="text"/>
10B	COG MECHANISM HOLDER	BM	FOUR 2.6 X 4MM PM SCREWS (1 spare)	<input type="text"/>
10C	SPRING	AP	FIVE 2.3 X 4MM PB SCREWS (1 spare)	<input type="text"/>
<input type="text"/>				<input type="text"/>

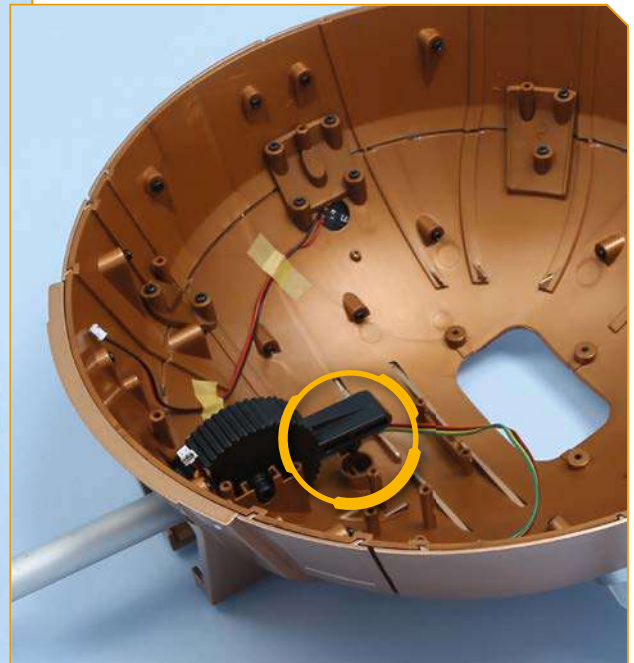
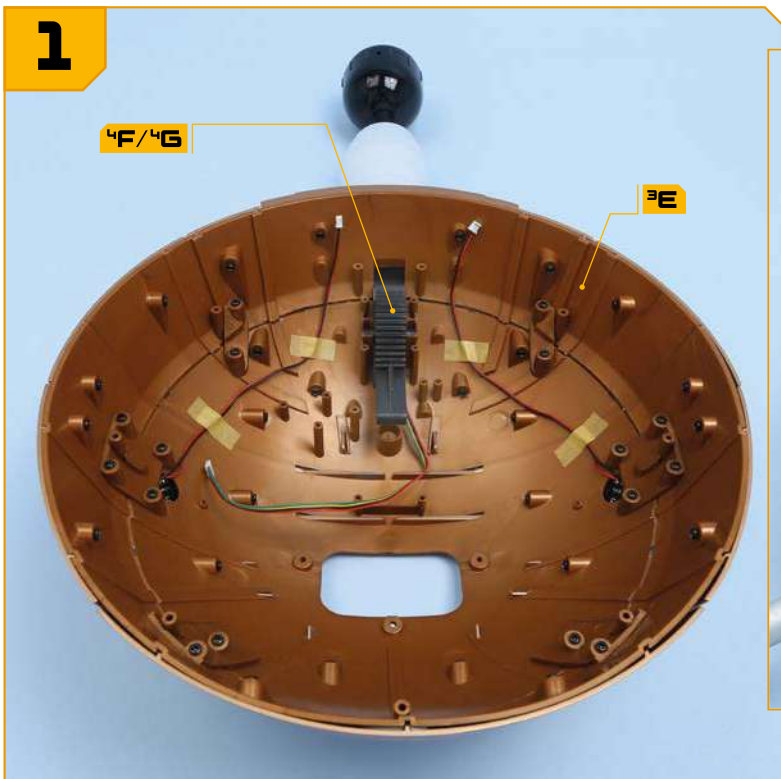
1**#10-01**

Take the dome assembly from the previous issue and check that the eye arm is the right way up. There is a shaped tab on part

4G (circled, above) which should point towards the dome. The spring **10C** is fitted over this in step 3.

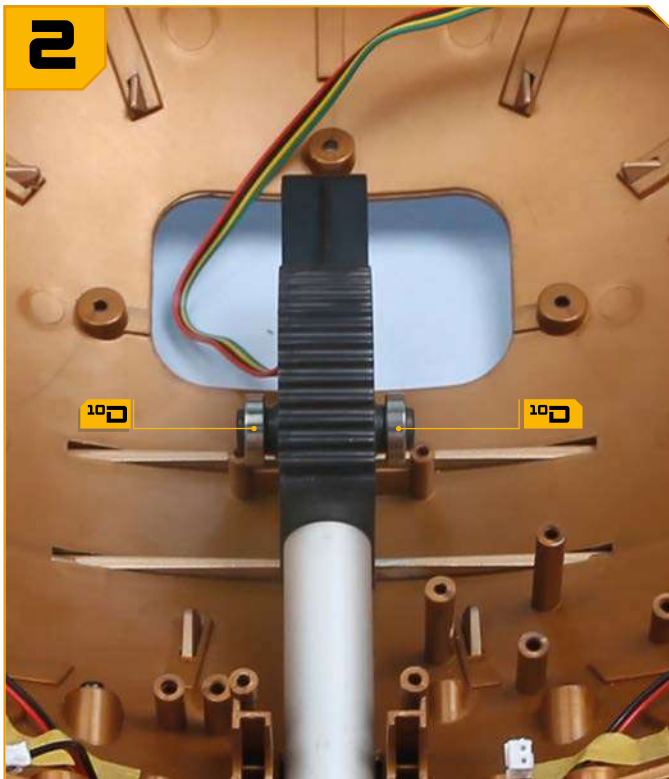
2**#10-02**

Take the two bearing rings **10D** and fit them on to the hubs on each side of the cog assembly (parts **4F** and **4G**).

#10-03

Fit the spring, **10C**, on to the shaped tab on part **4G** (circled in step 1). Position the bearing rings **10D** on the bearers on part **3F**. At the same time, the spring fits into a recess in part **3F**.

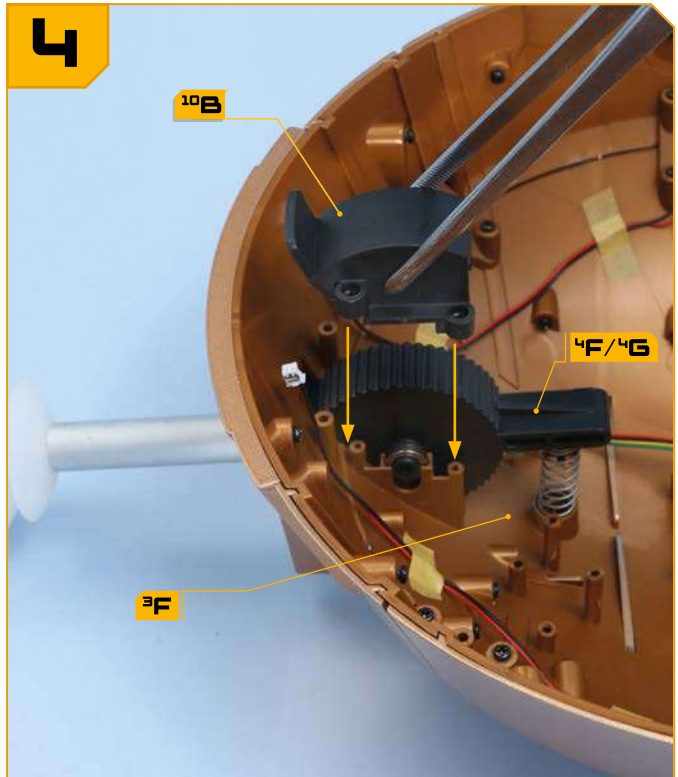
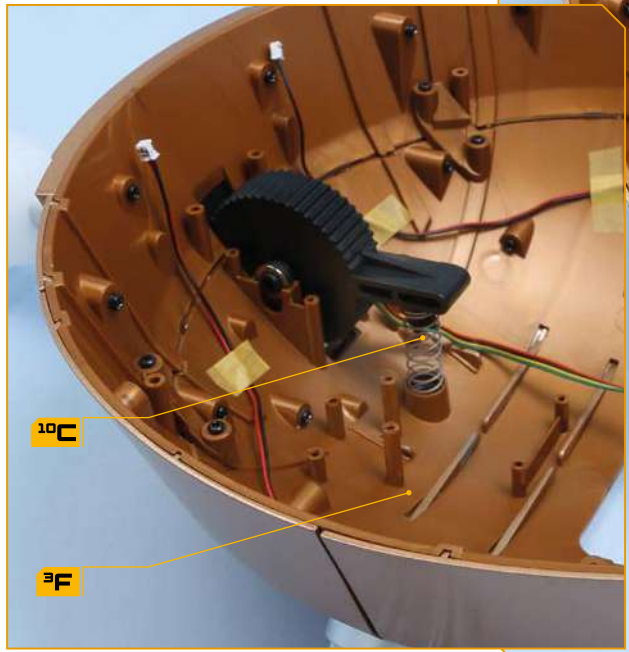
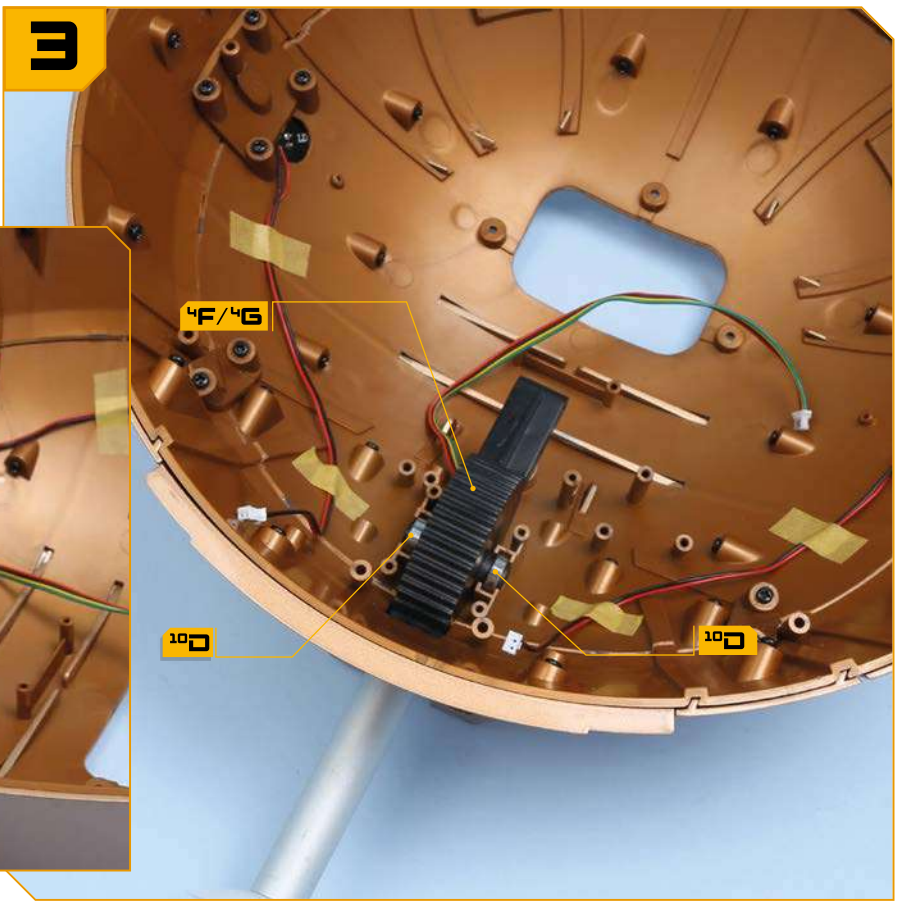

#10-04

Take the cog mechanism holder **10B** and fit it over the cog mechanism **4G** and **4F**, so that the screw holes in part **10B** align with screw sockets in the bearers on part **3F**.

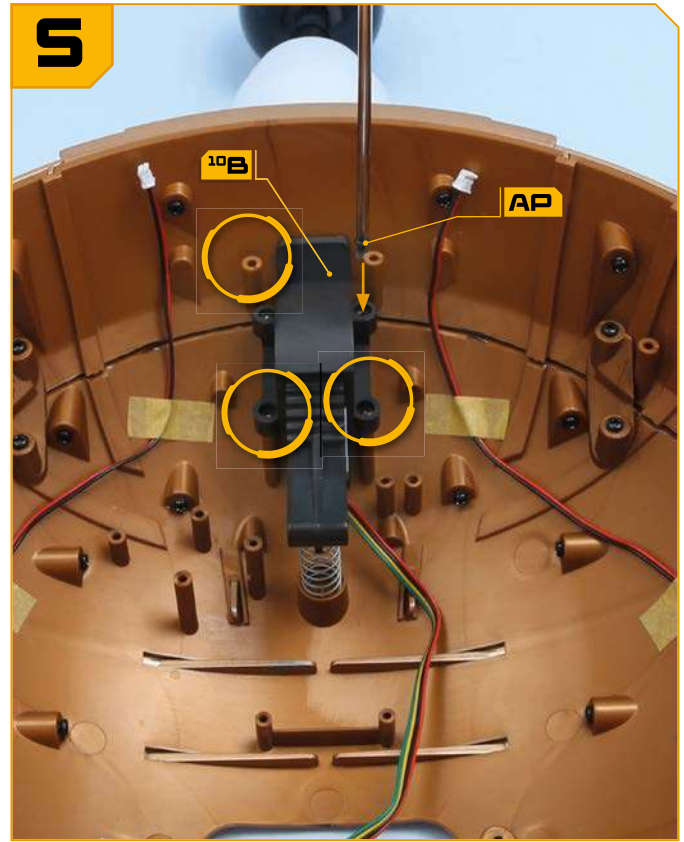

#10-05

Fix part **10B** in place with four **AP** screws.

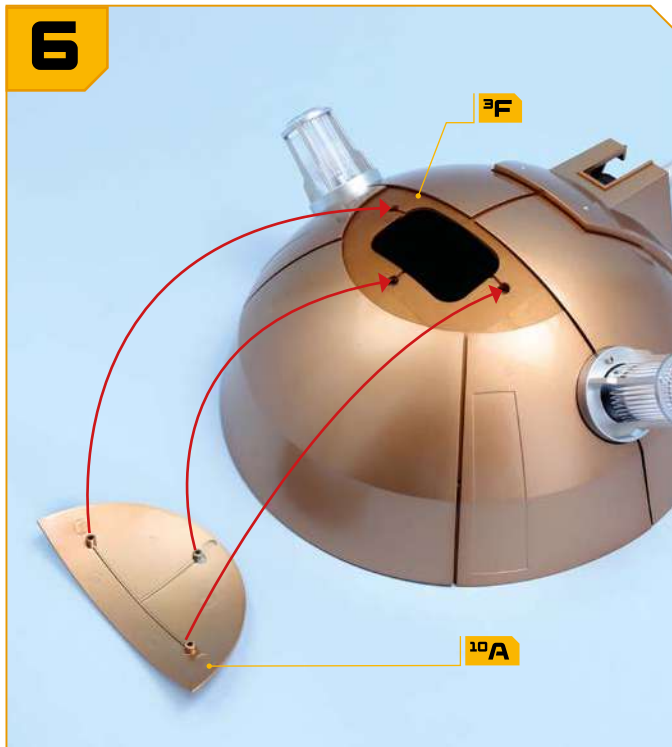

#10-06
Turn the dome right side up and check the fit of part **10A** on the top of the dome: three raised screw sockets on part **10A** fit into recesses in part **3F**.

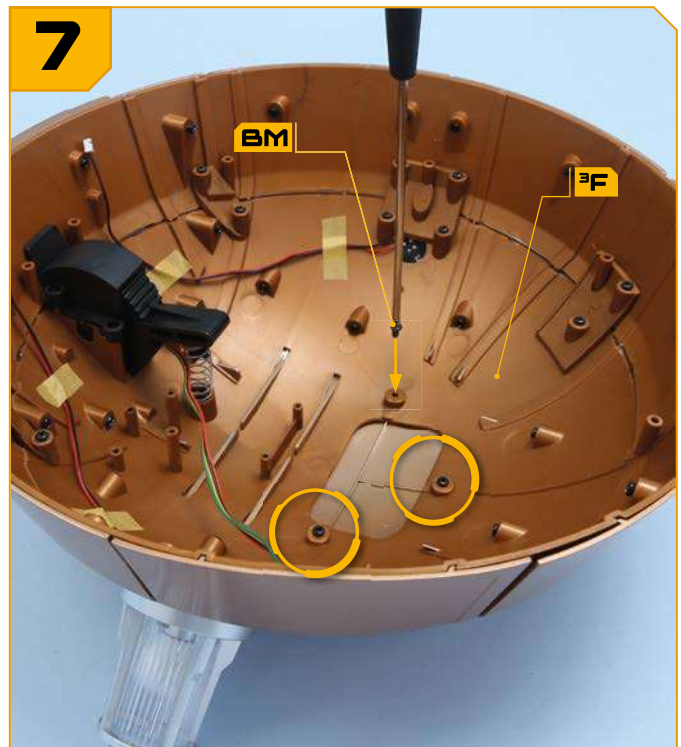

#10-07
Turn the dome upside down and identify the fixing points for part **10A**. Fix in place with three **BM** screws.

COMPLETED WORK

#10-COMPLETED WORK

The eye arm has been fixed in place and a panel has been fitted to the top of the dome.



THE DALEK

COMING IN
ISSUE 11

BUILD PART 11

The Eye stalk movement mechanism motor, attachment housing and fixing screws.



THE TIME VORTEX



Davros's right-hand man – his security chief, Nyder.

ADVENTURES IN TIME AND SPACE



The Doctor meets the Daleks for the first time in *The Survivors*.

Every week at your newsagent! Visit hachettepartworks.com/Dalek