

THE ICONIC FORD FALCON XB GT

SCALE
1:8



Front Wing Panel

Published weekly
UK: £10.99 AUS: \$21.99



POST-APOCALYPTIC EDITION

THE ICONIC FORD FALCON XB GT

ISSUE 97

ASSEMBLY GUIDE

3

The front left wing panel is fitted to the car body and the front bumper and skirt are fixed in place.

YOUR MODEL

You will be building a 1:8 scale replica of a customised 1973 Ford Falcon XB GT. Features include a lift-up bonnet that reveals a detailed engine, opening doors, wind-down windows and an 'active' steering wheel. A remote-control fob illuminates the main lights, brake lights and indicators.

Scale: 1:8
Length: 62cm
Width: 25cm
Height: 19cm
Weight: 7+kg



Official
Licensed Product

Ford Motor Company
trademarks and trade dress
used under licence to GRE
for Groupe ELIGOR

CUSTOMER SERVICE, SUBSCRIPTIONS & BACK ORDERS

Please visit hachettepartworks.com/contact to get in touch.

Published by Hachette Partworks Ltd
4th Floor, Jordan House, 47 Brunswick Place,
London, N1 6EB
www.hachettepartworks.com



© 2026 Hachette Partworks Ltd
© 2026 Ford Motor Company
Distributed in the UK and Republic of Ireland by Marketforce.
Printed in the United Kingdom
ISSN 2976-5811

Complete in 130 issues.

ALL RIGHTS RESERVED

Items may vary from those shown.
All parts belong to a kit. Collectors' item for adults. Not suitable for children under 14. Some parts may have sharp edges, please handle them with care.

The installation of electronic parts must always be carried out by an adult. When replacing batteries, use the same type of batteries. Please ensure that the battery compartment is securely fastened before you use the model again. Used batteries should be recycled. Please make sure to check with your local council how batteries should be disposed of in your area. Batteries can present a choking danger to small children and may cause serious harm if ingested. Do not leave them lying around and keep any spare batteries locked away at all times.

The editor's policy is to use papers that are natural, renewable and recyclable products and made from wood grown in sustainable forests. The logging and manufacturing processes are expected to conform to the environmental regulations of the country of origin.

In the event of a significant increase in production and transport costs, the publisher reserves the right to modify its selling prices.

MANAGING DIRECTOR – Isabelle Couderc
EDITORIAL DIRECTOR – Helen Nally
MARKETING DIRECTOR – Elise Windmill
PRODUCTION DIRECTOR – Sema Sant Anna
MANAGING EDITOR – Sarah Gale
PROJECT EDITOR – Gary Webb
DISTRIBUTION MANAGER – Paul Smith
PRODUCT MANAGER – Rhys Myner



For our
environmental
policy in full
please scan the
QR code here



**NOT SUITABLE FOR CHILDREN
UNDER THE AGE OF 14.**
This product is not a toy and is
not intended for use in play.

Editorial and design: Windmill Books Ltd

Picture credits:

Front cover: Jess Esposito and David Burton, main;
Richard Bryden, bl; Shutterstock, Steven Giles, background

Step-by-step photography: Richard Bryden

Model photography: Jess Esposito and David Burton

Windmill Books has made every attempt to contact the copyright holder, if you have any information please contact Sophie Mortimer: smortimer@windmillbooks.co.uk

Stage 97: Front Wing Panel

The left front wing panel is fitted to the car body and the front bumper and skirt are fixed in place.

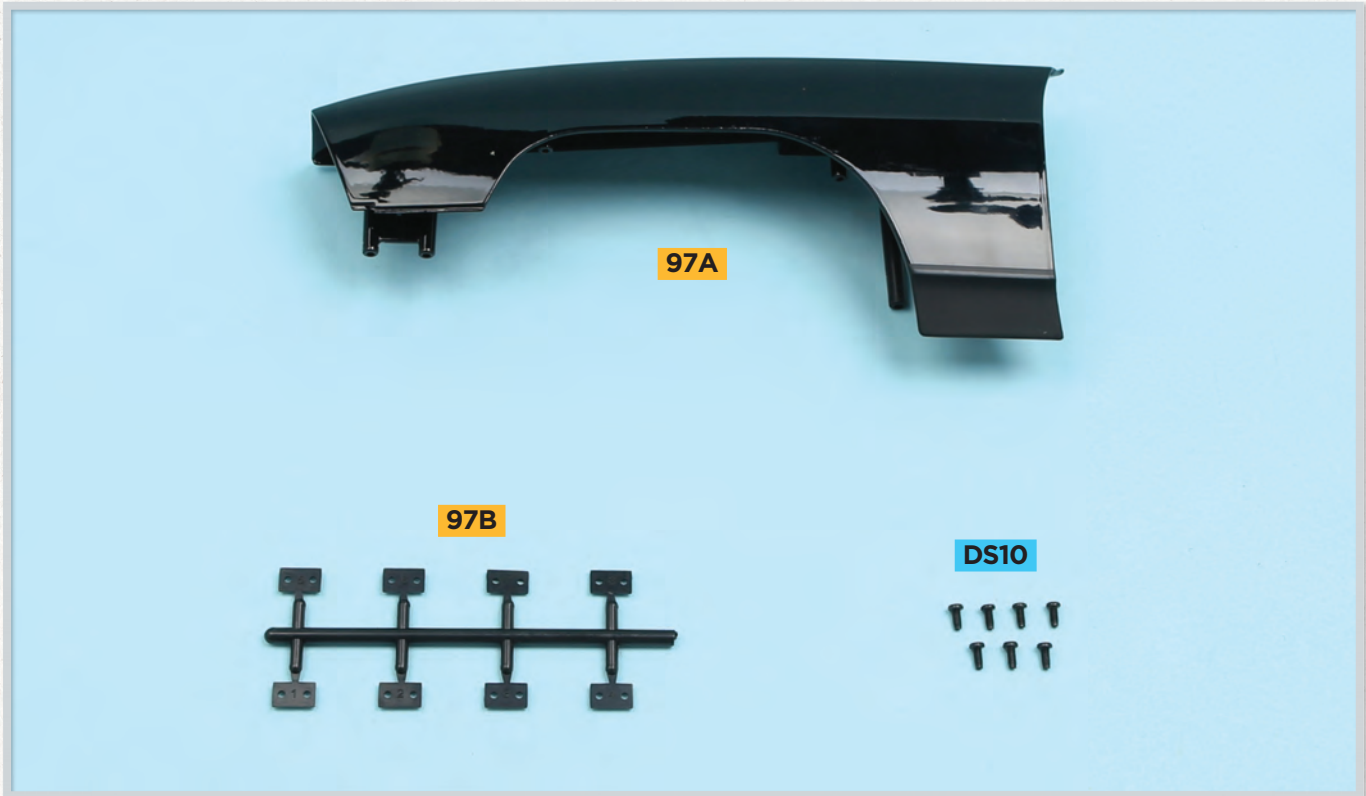

List of parts:

97A Left front wing panel

97B Cable grips (x 8*)

DS10 Seven* 2.3 x 5mm
PM screws

* Including spare

PM = Pan head for metal

Area of assembly



Stage 97: Front Wing Panel

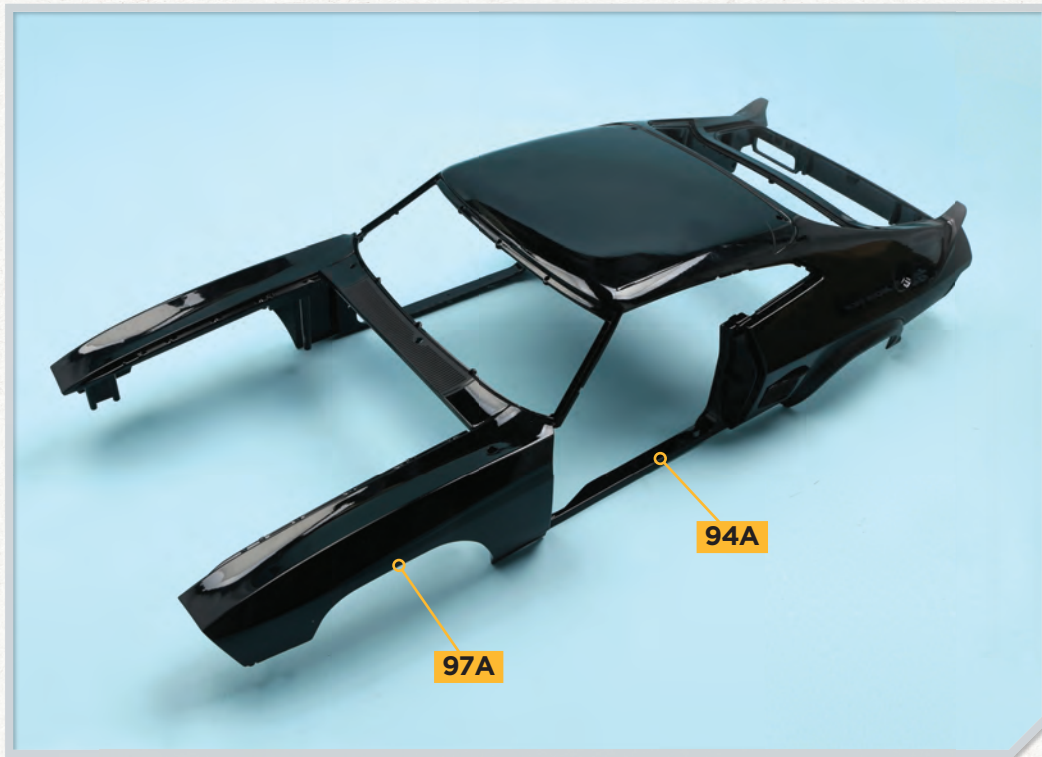

STEP 1

Take the left wing panel **97A** and check how it fits against the front of the car body assembly from the previous issue.



STEP 2

Carefully turn the assembly over so that you can access the inside of the car body. Identify the fixing points, where screw holes in part **97A** align with screw sockets in part **94A**. Fix the wing in place with two **DS10** screws.

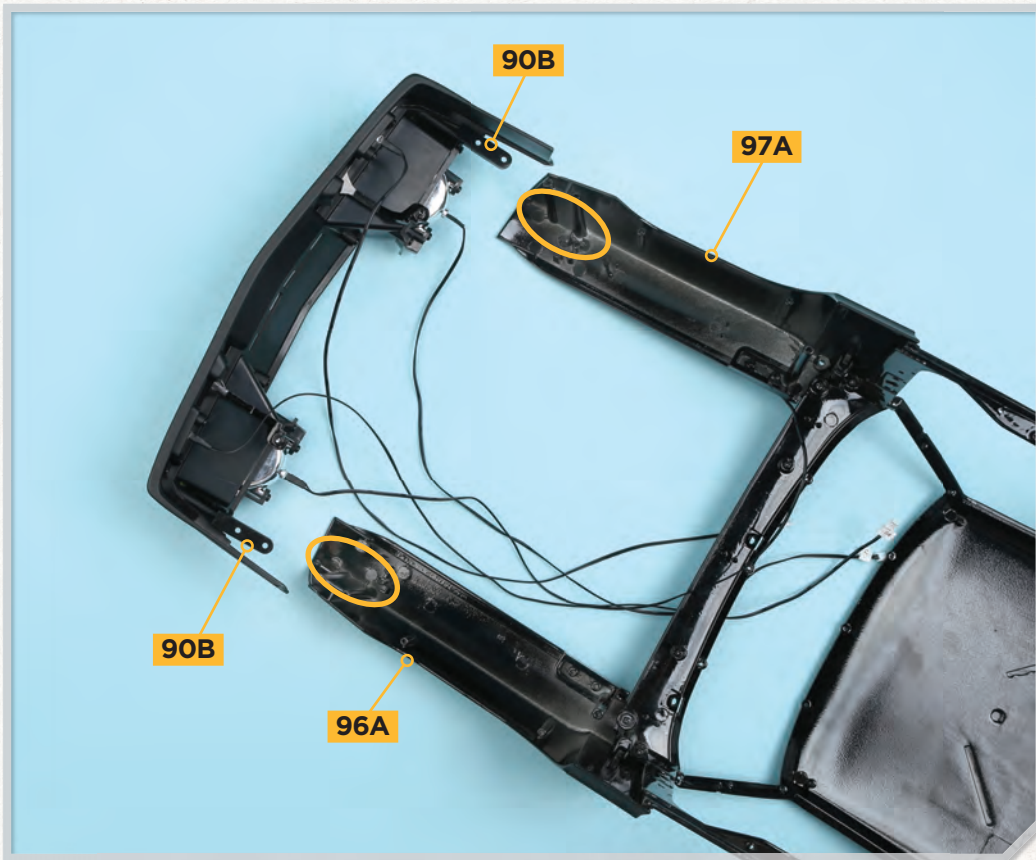

STEP 3

Take the front skirt assembly from issue 93 and check how it fits to the front of the wing panels **96A** and **97A**. The brackets **90B**, on the inside of the skirt, fit over raised screw sockets (circled) on the inside of the left and right wing panels.

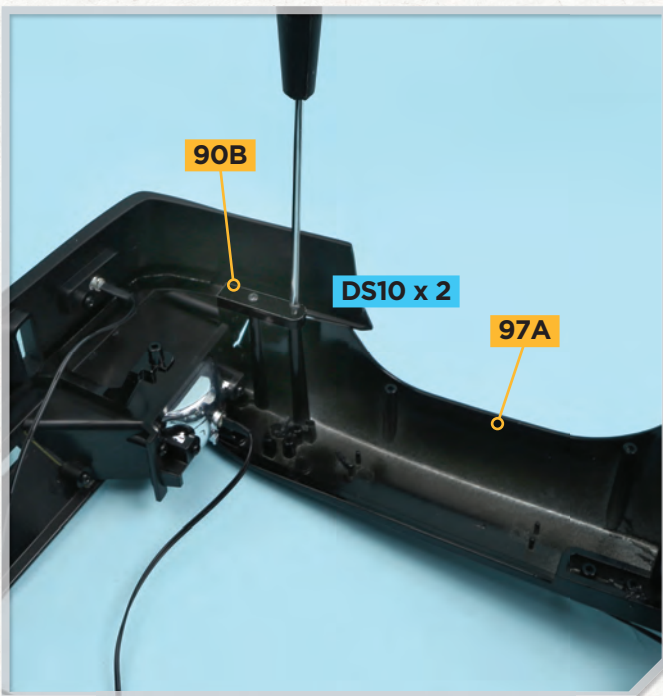

STEP 4

Fix the bracket **90B** to the left wing **97A** with two **DS10** screws.

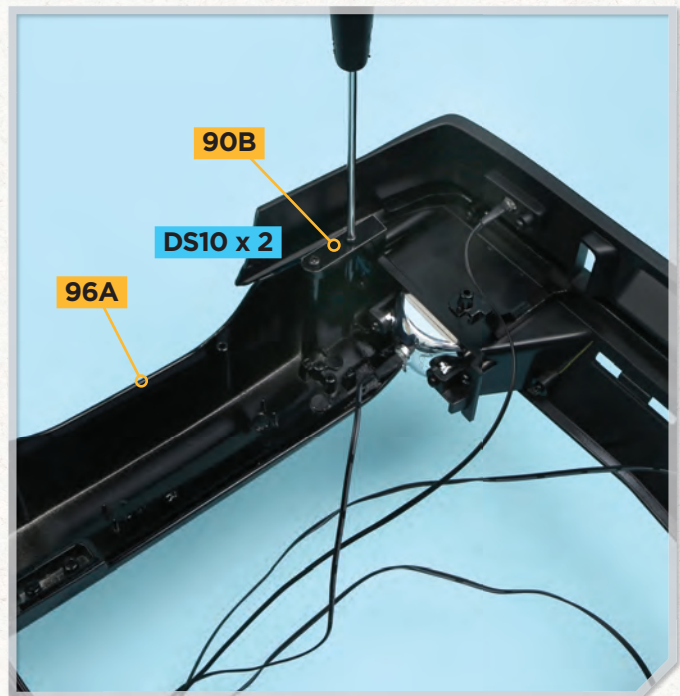

STEP 5

Fix the bracket **90B** to the right wing **96A** with two **DS10** screws.

Stage 97: Front Wing Panel



STEP 6

Remove the cable grips **97B** from the frame with a pair of sharp clippers.

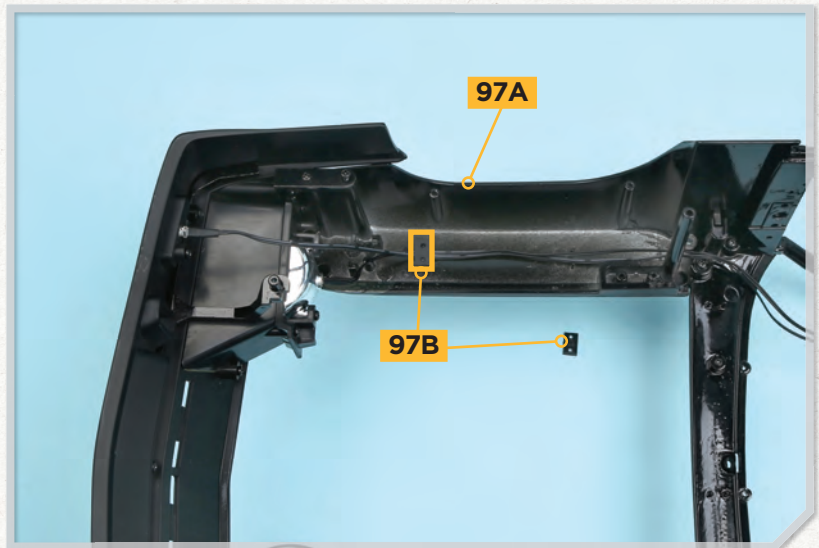

STEP 7

Take the left headlight and fog light cables (labelled 03 and 12) and run them between two small pegs on the inside of the left wing panel **97A**. Fit one of the cable grips **97B** to the pegs to hold the cables in place.

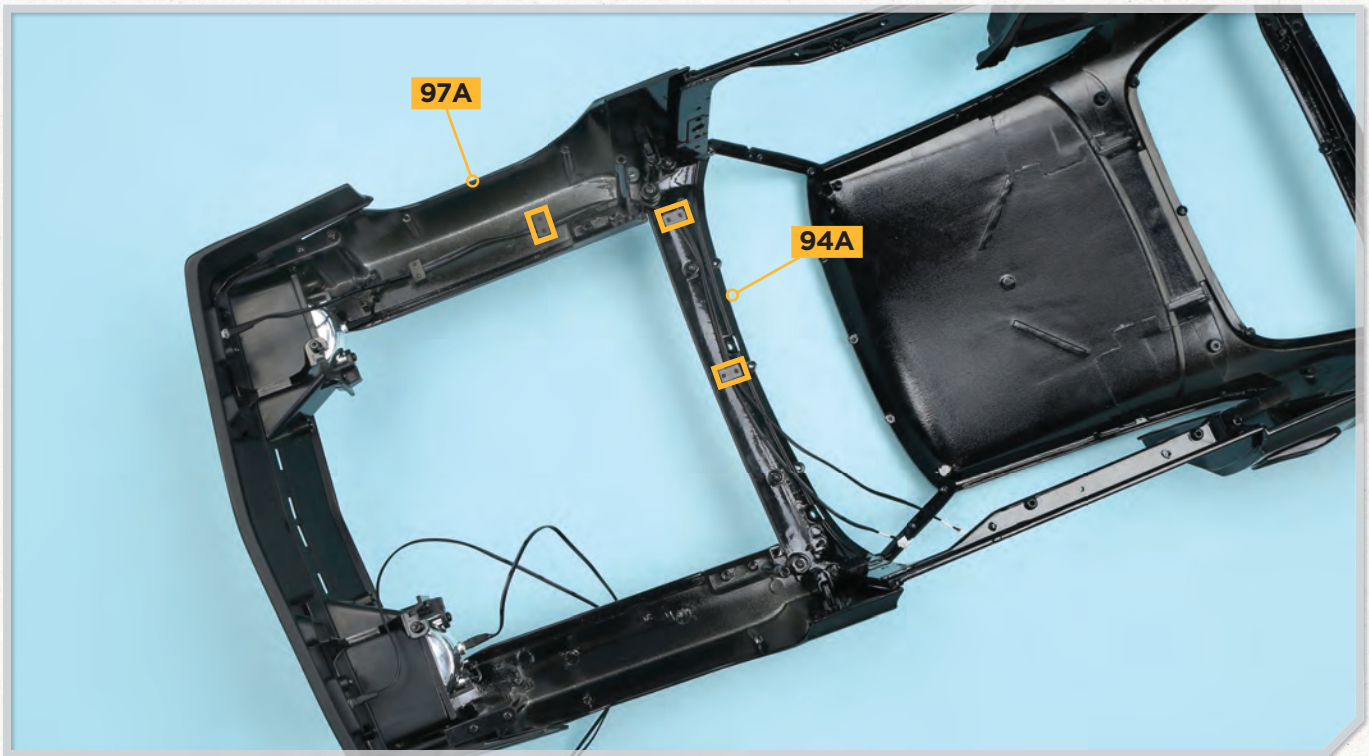

STEP 8

Continue running the cables around the inside of the wing panel **97A** and car body **94A**, as shown, fixing them in place with three more cable grips **97B** (outlined).

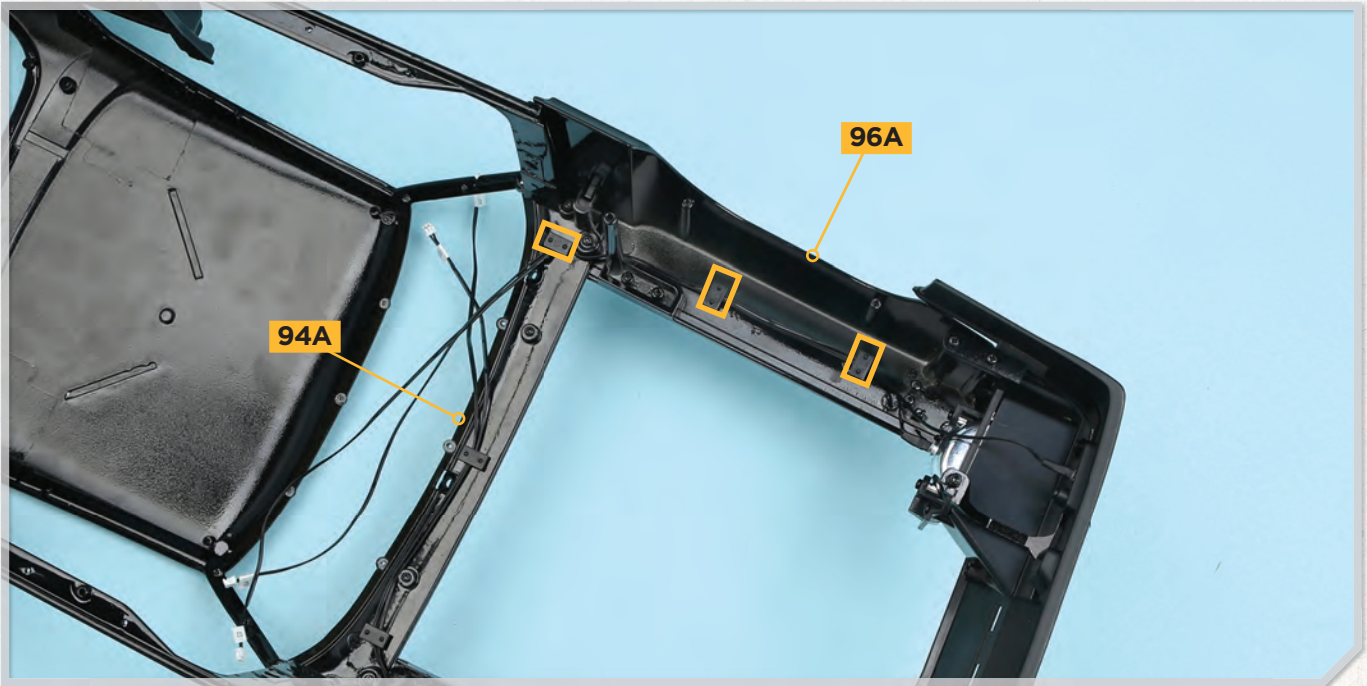

STEP 9

On the right-hand side of the model, gather the fog and headlight cables marked O4 and O2 and run them along the underside of the wing panel **96A** (between the pegs) and round to the front of the car body **94A**, fixing them in place with three cable grips **97B** (outlined).



COMPLETED ASSEMBLY

The left front wing has been fitted to the car body and the front skirt has been fixed in place.

COMING IN ISSUE 98



- **ASSEMBLY GUIDE**
Parts are fitted around the right door opening and the door is fixed in place on the car body.

NEW PARTS

Inner part of right door frame, right door threshold strip and screws.

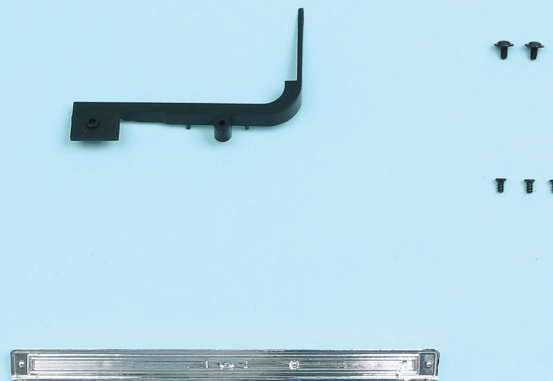

Published weekly
UK: £10.99
AUS: \$21.99



hachettepartworks.com/FordFalcon